

# MOTOROLA Chassis HS-1141 Tuner used in various models

(Tuner HK81 uses HS-1141 and is used with various models)

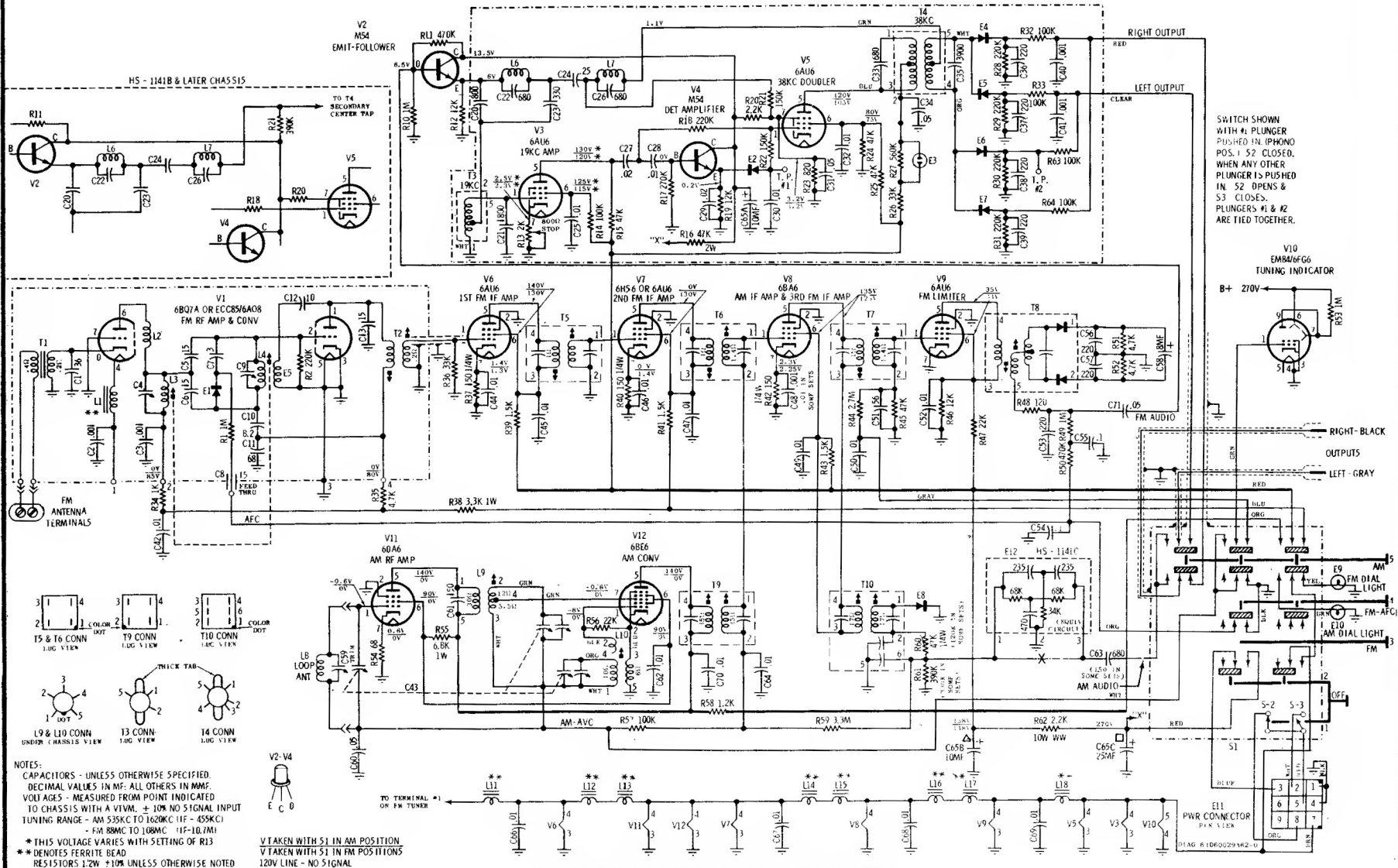

HS-1141 AM-FM TUNER REVISED SCHEMATIC

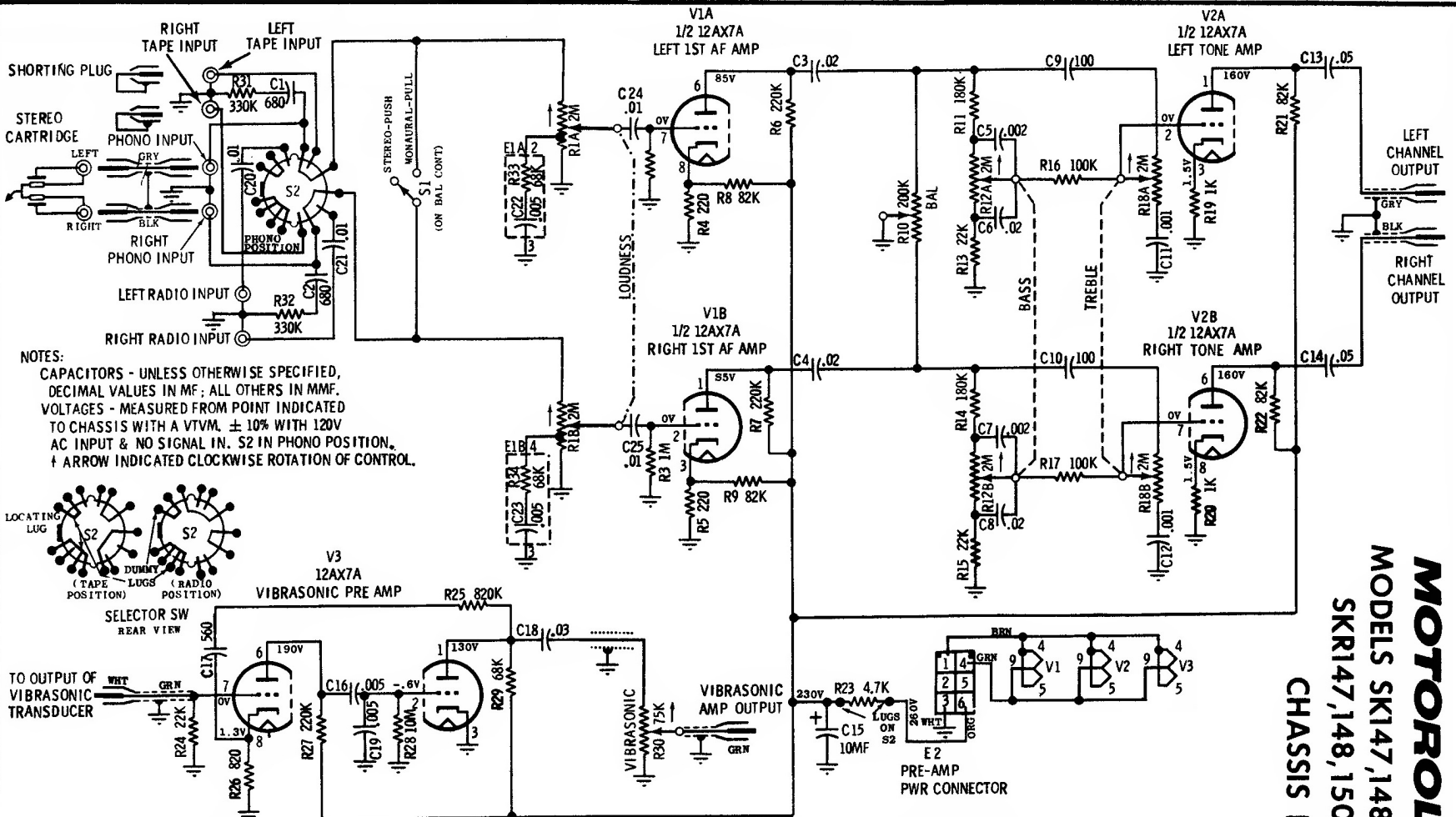

NOTES:  
 CAPACITORS - UNLESS OTHERWISE SPECIFIED, DECIMAL VALUES IN MF; ALL OTHERS IN MMF.  
 VOLTAGES - MEASURED FROM POINT INDICATED TO CHASSIS WITH A VTVM. ± 10% WITH 120V AC INPUT & NO SIGNAL IN. S2 IN PHONO POSITION.  
 † ARROW INDICATED CLOCKWISE ROTATION OF CONTROL.

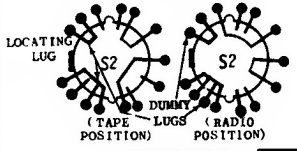

**CHASSIS REMOVAL (HS-1141)**

1. Remove cabinet back cover mounting screws and cabinet back cover.
2. On models that use a record well, remove the well as follows: Remove record well bezel by lifting straight up, then remove well by compressing top edges and pulling up.
3. Unplug all cables and leads; remove 2 chassis mounting wing nuts

and washers; then lift chassis out of cabinet.

**CHASSIS REMOVAL (HS-1197)**

1. On models that contain the built-in AM-FM tuner, HS-1141, it will be necessary to remove the HS-1141 as described above because the HS-1199 pre-amp is attached to it.
2. On models not containing the AM-FM tuner, remove the cabinet back cover as above, disconnect all cables, then remove the 2 chassis

mounting hex nuts and 2 rubber sleeves with eyelets and remove chassis from cabinet.

**CHASSIS REMOVAL (POWER AMP HS-1198)**

1. Remove cabinet back cover mounting screws and cabinet back cover.
2. Disconnect all cables, remove chassis mounting screws then the chassis.

**MOTOROLA**

MODELS SK147,148,150,154,164,165,  
 SKR147,148,150,153,154,164,165  
 CHASSIS HS-1141,1197,1198

# MOTOROLA Chassis HS-1198 Amplifier

RIGHT AUDIO LEFT AUDIO INPUT

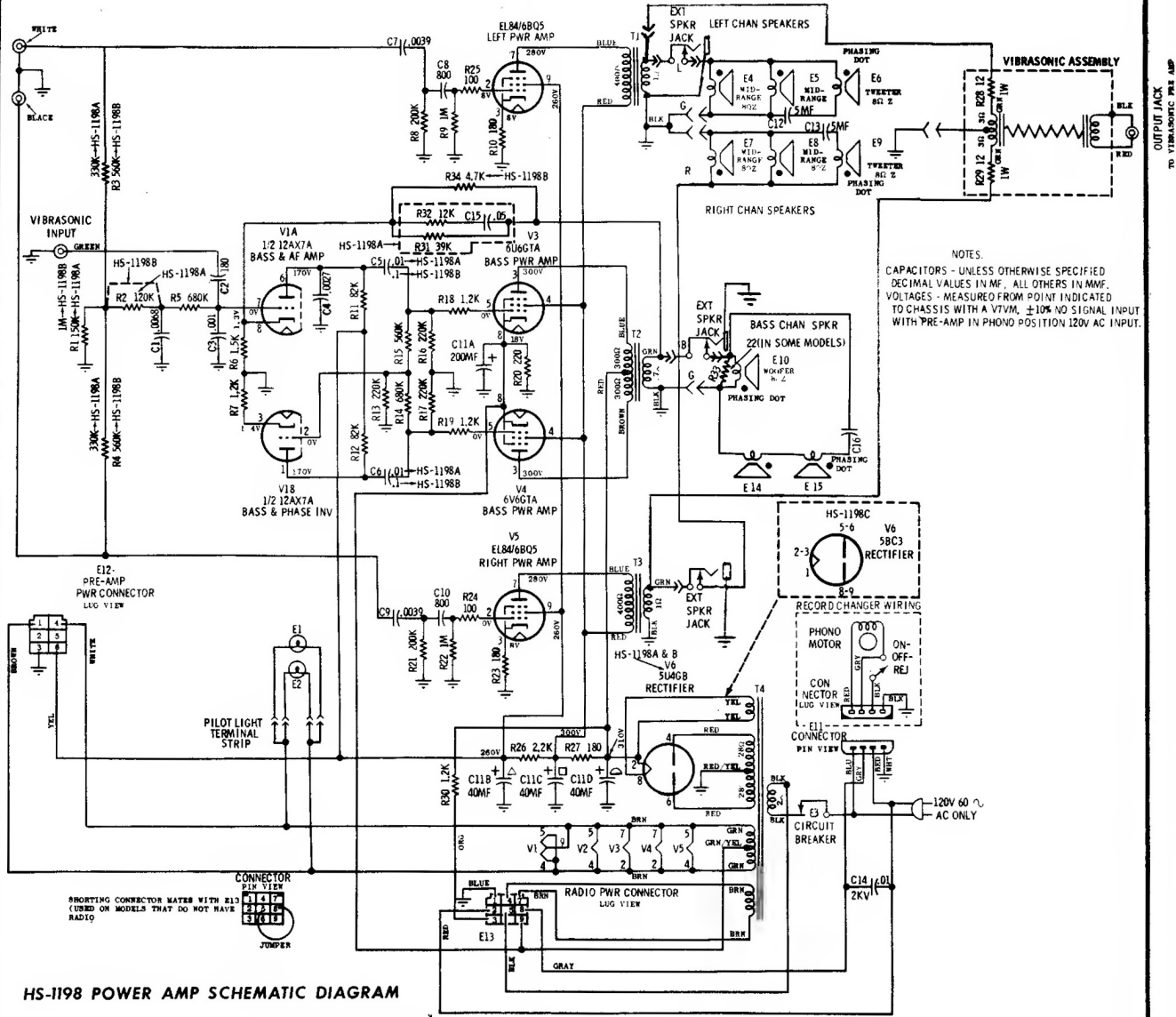

HS-1198 POWER AMP SCHEMATIC DIAGRAM

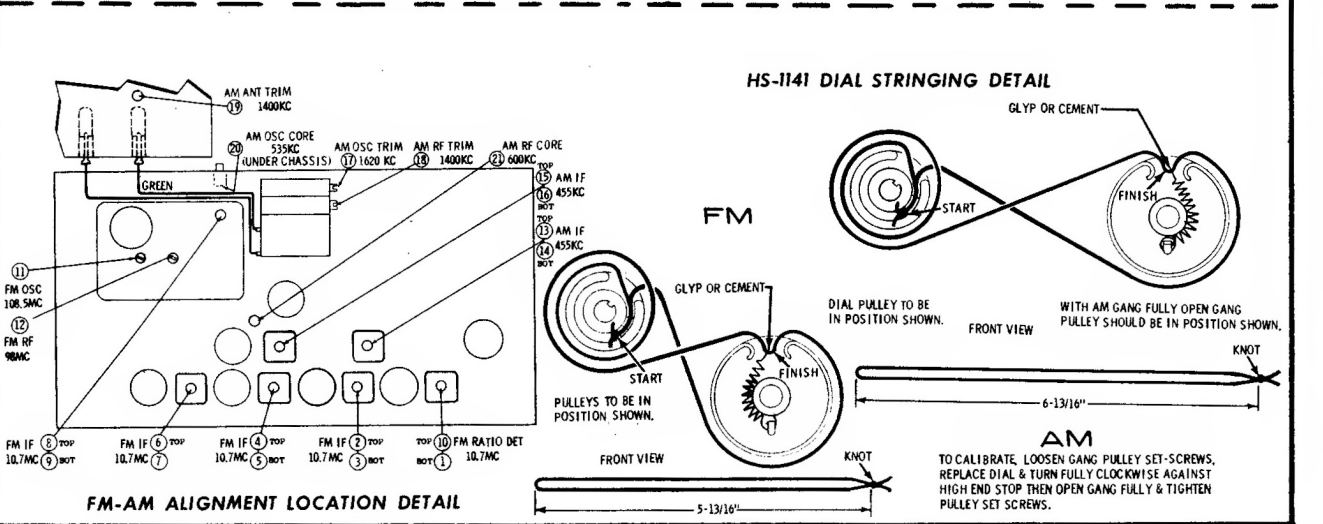

FM-AM ALIGNMENT LOCATION DETAIL

HS-1141 DIAL STRINGING DETAIL